

MARUYAMA

OWNER'S/OPERATOR'S MANUAL

**Mister
MM181**



Premium Outdoor Power Equipment



MARUYAMA *Extraordinary.*

Completely read and understand this manual prior to using this product.

TABLE OF CONTENTS

Foreword	1	Name of each part	12
Safety symbols	1	Operating instructions	15
Warning label	1	Regular maintenance	17
Warranty	2	Storage	19
Specifications	11	Emission control information	19
Assembly instructions	11		

FOREWORD

This Owner's/Operator's Manual is designed to familiarize the operator with the various features and component parts of the equipment and to assist you with the assembly, operation and maintenance of your new Backpack Mist Blower.

It is essential that any operator of this Backpack Mist Blower product reads and understands the contents of this manual before using the Backpack Mist Blower.

Important safety instructions will be identified by the following safety symbol:



Failure to comply with the instructions in this manual may result in serious injury or death.

For additional assistance, contact any local authorized Maruyama dealer or Maruyama U.S., Inc., 4770 Mercantile Drive, suite100, Fort Worth, TX 76137 U.S.A.

phone : 940-383-7400

web : www.maruyama-us.com

MANUAL SAFETY SYMBOLS

Throughout this manual and on the product itself, you will find safety alerts and helpful, information message preceded by symbols or key words. The following is an explanation of those symbols and key words and what they mean to you.



This symbol accompanied by the words **WARNING** and **DANGER** calls attention to an act or condition that can lead to serious personal injury to operator and bystanders.

Warning label

- Always remove dirt or mud to make the indications legible.
- The following alarm labels are attached.

Alarm label



Read Owner's/Operator's Manual thoroughly.
Make sure you read the Owner's/Operator's Manual thoroughly prior to use.



Prohibition of fire
Don't put a naked flame close to a place where supplying fuel or doing maintenance.



Wear a protector.
Wear protectors such as hat, safety glasses, ear plugs during work.



Cautions for exhaust gas.
Take care not to breathe in exhaust gas from the engine.



Cautions for high temperatures
Muffler of engine, fin of cylinder, etc. are at high temperatures. Don't touch them.



Limited Warranty Statement

All Maruyama commercial/ industrial products are warranted to the original purchaser to be free from defects in material and workmanship **from the date of purchase** for the time periods listed as follows:

Lifetime solid steel driveshaft and ignition coils.

5 years for qualified IRON 5-YR™ commercial, institutional, or industrial use.

1 year for residential or **2 years** for commercial use with competitor's oil. **90 days** for rental use.

Engine - Refer to engine manufacturer's warranty statement. Maruyama engines are covered by this limited warranty statement.

This warranty will be in full effect provided the engine is operated for the initial 80 hour optimization period using Maruyama Premium 2-Stroke oil. After the optimization period the engine should always be run with either Maruyama Premium 2-Stroke oil or equivalent ISO-L-EGD & JASO FD 2-Stroke oil.

Any part of a Maruyama product found to be defective within the applicable warranty period shall, at Maruyama's option, be repaired or replaced without charge. Warranty consideration is obtained by delivering any Maruyama product believed to be defective to an Authorized Maruyama Servicing Dealer within the applicable warranty period.

The purchaser shall not be charged for diagnostic labor that leads to the determination that a warranted part is defective, if the diagnostic work is performed at a Maruyama Dealer.

Any warranted part which is not scheduled for replacement as required maintenance, or which is scheduled only for regular inspection to the effect of "repair or replace as necessary" shall be warranted for the warranty period. Any warranted part, which is scheduled for replacement as, required maintenance shall be warranted for the period of time up to the first scheduled replacement point for that part.

Maruyama Mfg. Co., Inc. is liable for damages to other engine components caused by the failure of a warranted part still under warranty.

The purchaser is responsible for the performance of the required maintenance, as defined by Maruyama Mfg. Co., Inc. in the Owner's/Operator's Manual.

EMISSION-RELATED PARTS WARRANTY: In addition to the above warranty coverage, Maruyama Mfg. Co., Inc. will repair or replace, free of charge, for the original purchaser and each subsequent purchaser any emission-related part or parts found to be defective in material and workmanship for two (2) years from original retail delivery date **except catalytic converter. Catalytic converter is warranted one year from original retail delivery date. Emission-related parts are the carburetor assembly, the ignition coil assembly, the ignition rotor, the spark plug, the catalytic converter and the fuel tank.** Any replacement part that is equivalent in performance and durability may be used in non-warranty maintenance or repairs, and shall not reduce the warranty obligations of Maruyama Mfg. Co., Inc.

This warranty does not cover the following:

1. Maintenance items (excluding defects in materials and workmanship) including hoses, spark plugs, starter rope, air and fuel filters, clutch shoes, vibration isolators, throttle cables and all cutting attachments, etc.
2. Extra expenses including shipping and handling, travel, payment for lost time or pay and for any inconvenience and storage.
3. Alterations or modifications including aftermarket parts not authorized by Maruyama U.S., Inc.
4. Wear, accident, abuse, neglect, misuse, negligence, improper fuels, lubricants, fuel mixtures (when applicable), or failure to operate or maintain the product in accordance with instructions approved by Maruyama, repair or replacement as provided under this warranty is the exclusive remedy of the consumer.

Maruyama shall not be liable for any incidental or consequential damages for breach of any express or implied warranty on these products except to the extent prohibited by applicable law. Any implied warranty of merchantability or fitness for a particular purpose on these products is limited in duration to the warranty period as defined in the limited warranty statement. Maruyama reserves the rights to change or improve the design of the product without notice and does not assume obligation to update previously manufactured products.

This warranty provides you with specific legal rights, which may vary from state to state.

It is the Owner's and Dealer's responsibility to make sure the Warranty Registration Card is properly filled out and mailed to Maruyama U.S., Inc. Proof of purchase and registration will be required in order to obtain warranty service.

To locate an Authorized Maruyama Servicing Dealer nearest you, contact:

Maruyama U.S., Inc.
4770 Mercantile Drive, suite100,
Fort Worth, TX 76137 U.S.A.
940-383-7400
maruyama@maruyama-us.com
www.maruyama-us.com

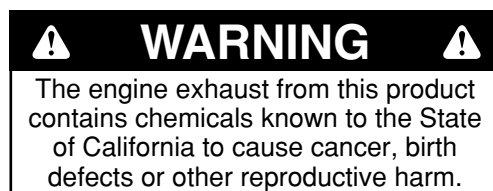

EMISSION CONTROL SYSTEM WARRANTY STATEMENT

This warranty statement outlines the emission warranty coverage provided by Maruyama., U.S. INC. (hereinafter "Maruyama") for small off-road engines sold in the U.S. and its territories, as well as the 13 provinces and territories of Canada. This warranty statement is divided into two parts. Part I warrants that a new Maruyama small off-road engine complies with U.S. EPA and Environment Canada emissions regulations. Part II warrants that a new Maruyama small off-road engine certified for sale in California also complies with the State of California's emissions regulations.

Part I: United States and Canada

Your Warranty Rights and Obligations

Your new small off-road engine must be designed, built and equipped to meet the U.S. EPA emission standards for small off-road engines with maximum engine power at or below 19 kilowatts or an engine displacement less than 1 liter. Maruyama must warrant the emission control system on your small off-road engine for the period of time listed below, provided there has been no abuse, neglect, or improper maintenance of your small off-road engine. Where a warrantable condition exists, Maruyama will repair your small off-road engine at no cost to you including diagnosis, parts, and labor.

Your emission control system may include such parts as the carburetor or fuel injection system, the ignition system, and catalytic converter. Also included may be hoses, connectors, and other emission-related assemblies. For a list of the emission control system parts covered under this warranty, please contact your nearest Maruyama Dealer or contact Maruyama directly at 1-866-783-7400 or warranty@maruyama-us.com.

Warranty Coverage

Maruyama warrants to the original retail purchaser, and each subsequent purchaser, that the small off-road engine, including all parts of its emission control system, is:

1. designed, built, and equipped to conform to the U.S. EPA and Environment Canada emission standards at the time of sale to the original retail purchaser; and
2. free from defects in materials and workmanship that may keep it from meeting the requirements under these emission standards.

This warranty begins on the date the small off-road engine is delivered to the original retail purchaser and extends for a period of five (5) years. This warranty covers all components whose failure would increase the emissions of any regulated pollutant. This warranty does not cover components whose failure would not increase the engine's emissions of any regulated pollutants.

Owner's Warranty Responsibility

As the small off-road engine owner, you are responsible for the performance of the required maintenance listed in your owner's manual. Maruyama recommends that you retain all receipts covering maintenance on your small off-road engine, but Maruyama cannot deny warranty coverage solely for the lack of receipts or for your failure to ensure the performance of all scheduled maintenance.

As the small off-road engine owner, you should, however, be aware that Maruyama may deny you warranty coverage if your small off-road engine or a part has failed due to abuse, neglect, improper maintenance, or unapproved modifications.

You are responsible for presenting your small off-road engine to a Maruyama dealer as soon as a problem exists. The emission related warranty repairs should be completed in a reasonable amount of time, not to exceed 30 days.

If you have any questions regarding your emission warranty rights and responsibilities, you should contact:

Maruyama.,U.S. INC.
4770 Mercantile Drive, suite 100
Fort Worth, TX 76137 U.S.A.
Telephone: 1-866-783-7400
Email: warranty@maruyama-us.com

To Obtain Warranty Service

You must, at your own expense, take your Maruyama small off-road engine or the product on which it is installed, along with proof of original purchase date, to any Maruyama Dealer who is authorized by Maruyama to sell and service that Maruyama product during the Dealer's normal business hours. Claims for repair or adjustments found to be caused solely by defects in material or workmanship will not be denied because the engine was not properly maintained and used.

If however, you reside more than 100 miles from an authorized service center in the contiguous states, excluding certain high-altitude areas, Maruyama will either pay for shipping costs to and from an authorized service center, provide for a service technician to come to the owner to make the warranty repair, or pay for the repair to be made at a local non-authorized service center. If you are unable to obtain emission warranty service or are dissatisfied with the warranty service you received, contact the owner of the dealership involved. However, if you require further assistance, contact Maruyama directly via the contact information above.

Exclusions

Failures other than those resulting from defects in material or workmanship are not covered by this warranty. This warranty does not extend to emission control systems and parts that are affected or damaged by owner abuse, misuse, neglect, improper maintenance or repairs, misfueling, improper storage, collision, the use of unsuitable attachments, or the unauthorized alteration of any part.

This warranty does not cover replacement of parts or other services and adjustments necessary for required maintenance at and after the first scheduled replacement point.

Disclaimer of Consequential Damages and Limitation of Implied Warranties

Maruyama., U.S. INC. disclaims responsibility for incidental or consequential damages such as loss of time or the use of the power equipment, or any commercial loss due to the failure of the equipment; and any implied warranties are limited to the duration of this written warranty. This warranty is applicable only where the California, U.S. EPA, or Environment Canada emission control system warranty regulation is in effect.

Part II: CALIFORNIA EMISSIONS CONTROL WARRANTY STATEMENT

Your Warranty Rights and Obligations

The California Air Resources Board and Maruyama are pleased to explain the emission control system warranty on your model year 2015/2016 small off-road engine. In California, new small off-road engines must be designed, built, and equipped to meet the State's stringent anti-smog standards. Maruyama must warrant the emission control system on your small off-road engine for the periods of time listed below provided there has been no abuse, neglect or improper maintenance of your small off-road engine.

Your emission control system may include such parts as the carburetor or fuel injection system, the ignition system, and catalytic converter. Also included may be fuel tanks, fuel lines, fuel caps, canisters, hoses, belts, connectors, and other emission-related assemblies.

Where a warrantable condition exists, Maruyama will repair your small off-road engine at no cost to you including diagnosis, parts and labor.

Manufacturer's Warranty Coverage

The 1995 and later small off-road engines are warranted for five (5) years. If any emission-related part on your small off-road engine is defective, the part will be repaired or replaced by Maruyama.

Owner's Warranty Responsibility

As the small off-road engine owner, you are responsible for the performance of the required maintenance listed in your owner's manual. Maruyama recommends that you retain all receipts covering maintenance on your small off-road engine, but Maruyama cannot deny warranty coverage solely for the lack of receipts or for your failure to ensure the performance of all scheduled maintenance.

As the small off-road engine owner, you should however be aware that Maruyama may deny you warranty coverage if your small off-road engine or a part has failed due to abuse, neglect, improper maintenance, or unapproved modifications.

You are responsible for presenting your small off-road engine to a Maruyama distribution center as soon as a problem exists. The warranty repairs should be completed in a reasonable amount of time, not to exceed 30 days.

If you have any questions regarding your warranty rights and responsibilities, you should contact:

Maruyama.,U.S. INC.
4770 Mercantile Drive, suite 100
Fort Worth, TX 76137 U.S.A.
Telephone: 1-866-783-7400
Email: warranty@maruyama-us.com

General Emissions Warranty Coverage

Maruyama warrants to the ultimate purchaser and each subsequent purchaser that the small off-road engine is:

1. designed, built, and equipped so as to conform with all applicable regulations adopted by the Air Resources Board pursuant to its authority in Chapters 1 and 2, Part 5, Division 26 of the Health and Safety Code; and
2. free from defects in materials and workmanship that cause the failure of a warranted part to be identical in all material respects to the part as described in Maruyama's application for certification.

The warranty period begins on the date the engine or equipment is delivered to an ultimate purchaser or first placed into service. The equipment or engine owner will not be charged for diagnostic labor that is directly associated with diagnosis of a defective, emission-related warranted part, provided that such diagnostic work is performed at a Maruyama warranty station.

Engine parts outlined in the Periodic Maintenance Chart found in the Owners Manual provided with this engine, are warranted as follows:

1. Any warranted part that is not scheduled for replacement as required maintenance in the Periodic Maintenance Chart, is warranted for the warranty period stated above. If any such part fails during the warranty period, the part will be repaired or replaced by Maruyama at no charge to the owner provided the repair or replacement is performed at a warranty station. Any such part repaired or replaced under the warranty will be warranted for the remaining warranty period.
2. Any warranted part that is scheduled only for regular inspection in the Periodic Maintenance Chart is warranted for the warranty period stated above. Any such part repaired or replaced under warranty will be warranted for the remaining warranty period.
3. Any warranted part that is scheduled for replacement as required maintenance in the Periodic Maintenance Chart is warranted for the period of time before the first scheduled replacement date for that part. If the part fails before the first scheduled replacement, the part will be repaired or replaced by Maruyama at no charge to the owner provided the repair or replacement is performed at a warranty station. Any such part repaired or replaced under warranty will be warranted for the remainder of the period prior to the first scheduled replacement point for the part.

Maruyama is liable for damages to other engine components proximately caused by a failure under warranty of any warranted part.

Throughout the engine's warranty period defined above, Maruyama will maintain a supply of warranted parts sufficient to meet the expected demand for such parts. Any replacement part may be used in the performance of any warranty maintenance or repairs and will be provided without charge to the owner. Such use will not reduce the warranty obligations of Maruyama.

Add-on or modified parts, as defined in Section 1900(b)(1) and (b)(10), Title 13, that are not exempted by the Air Resources Board may not be used. The use of any non-exempted add-on or modified parts by the ultimate purchaser will be grounds for disallowing a warranty claim made in accordance with this article. Maruyama will not be liable under this article to warrant failures of warranted parts caused by the use of a non-exempted add-on or modified part.

To Obtain Warranty Service

Notwithstanding the provisions herein, warranty services or repairs will be provided at all Maruyama distribution centers that are franchised to service the subject engines.

You must, at your own expense, take your Maruyama small off-road engine or the product on which it is installed, along with proof of original purchase date, to any Maruyama Dealer who is authorized by Maruyama to sell and service that Maruyama product during the Dealer's normal business hours. Claims for repair or adjustments found to be caused solely by defects in material or workmanship will not be denied because the engine was not properly maintained and used.

If you are unable to obtain emission warranty service or are dissatisfied with the warranty service you received, contact the owner of the dealership involved. However, if you require further assistance, contact the Maruyama office in your region:

Maruyama.,U.S. INC.
4770 Mercantile Drive, suite 100
Fort Worth, TX 76137 U.S.A.
Telephone: 1-866-783-7400
Email: warranty@maruyama-us.com

Exclusions

- (1) The repair or replacement of any warranted part otherwise eligible for warranty coverage as stated above may be excluded from such warranty coverage if Maruyama demonstrates that the engine has been abused, neglected, or improperly maintained, and that such abuse, neglect, or improper maintenance was the direct cause of the need for repair or replacement of the part.
- (2) Maruyama warrants your engine only for the warranty period specified above.
- (3) Except as provided above, any adjustment of a component that has a factory installed, and properly operating, adjustment limiting device (such as an idle limiter cap or plug) is eligible for warranty coverage as stated above.

Disclaimer of Consequential Damage and Limitation of Implied Warranties:

Maruyama., U.S. INC. disclaims responsibility for incidental or consequential damages such as loss of time or the use of the power equipment, or any commercial loss due to the failure of the equipment; and any implied warranties are limited to the duration of this written warranty. This warranty is applicable only where the California, U.S. EPA, or Environment Canada emission control system warranty regulation is in effect.

Warranted Parts List:

The following is the emission warranty parts list for your small off-road engine:

- (i) Fuel Metering System
 - (A) Carburetor and internal parts (and/or pressure regulator or fuel injection system)
 - (B) Cold start enrichment system
 - (C) Intake valve(s)
- (ii) Air Induction System
 - (A) Intake manifold
 - (B) Air filter
- (iii) Ignition System
 - (A) Spark plugs
 - (B) Magneto or electronic ignition system
 - (C) Spark advance/retard system
 - (D) Ignition coil and/or control module
- (iv) Lubrication System
 - (A) Oil pump and internal parts
- (v) Positive Crankcase Ventilation (PCV) System
 - (A) PCV valve
 - (B) Oil filler cap
- (vi) Catalyst or Thermal Reactor System
 - (A) Catalytic converter
 - (B) Exhaust manifold
 - (C) Exhaust valve(s)
- (vii) Evaporative Emissions System
 - (A) Fuel tank
 - (B) Fuel cap
 - (C) Fuel line
 - (D) Carbon canister
 - (E) Purge port connector
- (viii) Miscellaneous Items Used in Above Systems
 - (A) Hoses, clamps, fittings, tubing, sealing gaskets or devices, and mounting hardware
 - (B) Pulleys, belts and idlers
 - (C) Vacuum, temperature, check, and time sensitive valves and switches
 - (D) Electronic Controls

Emissions related parts may vary from model to model. Certain models may not contain all of those parts and certain models may contain functionally equivalent parts.

FEDERAL EMISSION CONTROL WARRANTY STATEMENT

YOUR WARRANTY RIGHTS AND OBLIGATIONS

The U.S. Environmental Protection Agency (EPA) and Maruyama U.S., Inc. are pleased to explain the emission control system warranty on your small off-road engine. New 1997 and later model year small off-road engines must be designed, built and equipped, at the time of sale, to meet the U.S. EPA regulations for small off-road engines. The equipment engine must be free from defects in materials and workmanship which cause it to fail to conform with U.S. EPA standards for the first two years of engine use from the date of sale to the ultimate purchaser. Maruyama U.S., Inc. must warrant the emission control system on your small off-road engine for the period of time listed above provided there has been no abuse, neglect or improper maintenance of your small off-road engine.

Emission durability of 300 hours.

Your emission control system may include parts such as the carburetor or fuel injection system, the ignition system, and catalytic converter. Also included may be hoses, belts, and connectors and other emission related assemblies.

Where a warrantable condition exists, Maruyama U.S., Inc. will repair your small off-road engine at no cost to you, including diagnosis (if the diagnostic work is performed at an authorized dealer), parts, and labor.

MANUFACTURER'S WARRANTY COVERAGE:

The 1995 and later model year small off-road engines are warranted for five years. If any emission-related part on your engine is defective, the part will be repaired or replaced by Maruyama U.S., Inc. free of charge.

OWNER'S WARRANTY RESPONSIBILITIES:

(a) As the small off-road engine owner, you are responsible for the performance of the required maintenance listed in your owner's manual.

Maruyama U.S., Inc. recommends that you retain all receipts covering maintenance on your small off-road engine, but Maruyama U.S., Inc. cannot deny warranty solely for the lack of receipts or for your failure to ensure the performance of all scheduled maintenance. Any replacement part or service that is equivalent in performance and durability may be used in non-warranty maintenance or repairs, and shall not reduce the warranty obligations of the engine manufacturer.

(b) As the small off-road engine owner, you should be aware, however, that Maruyama Manufacturing Company may deny you warranty coverage if your small off-road engine or a part has failed due to abuse, neglect, improper maintenance or unapproved modifications.

(c) You are responsible for presenting your small off-road engine to a Maruyama U.S., Inc. service center as soon as a problem exists. The warranty repairs should be completed in a reasonable amount of time, not to exceed 30 days.

If you have any questions regarding your warranty rights and responsibilities, you should contact Maruyama U.S., Inc. at **1-866-783-7400, or warranty@maruyama-us.com**.

COVERAGE

Maruyama U.S., Inc. warrants to the ultimate purchaser and each subsequent purchaser that your small off-road engine will be designed, built and equipped, at the time of sale, to meet all applicable regulations. Maruyama U.S., Inc. also warrants to the initial purchaser and each subsequent purchaser that your small off-road engine is free from defects in materials and workmanship which cause the engine to fail to conform with applicable regulations for a period of two years.

The 1995 and later model years, EPA requires manufacturers to small off-road engines for two years. These warranty periods will begin on the date the small off-road engine is purchased by the initial purchaser. If any emission-related part on your engine is defective, the part will be replaced by Maruyama U.S., Inc. at no cost to the owner.

Maruyama U.S., Inc. shall remedy warranty defects at any authorized Maruyama U.S., Inc. engine dealer or warranty station. Any authorized work done at an authorized dealer or warranty station shall be free of charge to the owner if such work determines that a warranted part is defective. Any manufacturer-approved or equivalent replacement part may be used for any warranty maintenance or repairs on emission-related parts, and must be provided free of charge to the owner if the part is still under warranty, Maruyama U.S., Inc. is liable for damages to other engine components caused by the failure of a warranted part still under warranty.

EPA considers emission-related warranted parts to include all the parts listed below. These warranted parts are: the carburetor assembly, the ignition coil assembly, the ignition rotor, the spark plug, the catalytic converter, and the fuel tank.

MAINTENANCE REQUIREMENTS

The owner is responsible for the performance of the required maintenance as defined by the Maruyama U.S., Inc. in the owner's manual.

LIMITATIONS

This Emission Control System Warranty shall not cover any of the following:

- (a) repair or replacement required because of misuse or neglect, lack of required maintenance, repairs improperly performed or replacements not conforming to Maruyama U.S., Inc. specifications that adversely affect performance and/or durability, and alterations or modifications not recommended or approved in writing by Maruyama U.S., Inc. and
- (b) replacement of parts and other services and adjustments necessary for required maintenance at and after the first scheduled replacement point.

CALIFORNIA EMISSION CONTROL WARRANTY STATEMENT YOUR WARRANTY RIGHTS AND OBLIGATIONS

The California Air Resources Board (CARB), and Maruyama U.S., Inc. are pleased to explain the emission control system warranty on your 2016 small off-road engine. In California, new small off-road engines must be designed, built and equipped to meet the State's stringent anti-smog standards. Maruyama U.S., Inc. must warrant the emission control system on your small off-road engine for the period of time listed above provided there has been no abuse, neglect or improper maintenance of your small off-road engine.

Your emission control system may include parts such as the carburetor or fuel injection system, the ignition system, fuel tank and catalytic converter. Also included may be hoses, belts, and connectors and other emission related assemblies.

Where a warrantable condition exists, Maruyama U.S., Inc. will repair your small off-road engine at no cost to you, including diagnosis, parts, and labor.

MANUFACTURER'S WARRANTY COVERAGE:

The 1995 and later small off-road engines are warranted for five years. If any emission-related part on your engine is defective, the part will be repaired or replaced by Maruyama U.S., Inc.

OWNER'S WARRANTY RESPONSIBILITIES:

- (a) As the small off-road engine owner, you are responsible for the performance of the required maintenance listed in your owner's manual. Maruyama U.S., Inc. recommends that you retain all receipts covering maintenance on your small off-road engine, but Maruyama U.S., Inc. cannot deny warranty solely for the lack of receipts or for your failure to ensure the performance of all scheduled maintenance
- (b) As the small off-road engine owner, you should be aware, however, that Maruyama Manufacturing Company may deny you warranty coverage if your small off-road engine or a part has failed due to abuse, neglect, improper maintenance or unapproved modifications.
- (c) You are responsible for presenting your small off-road engine to a Maruyama U.S., Inc. distribution center as soon as a problem exists. The warranty repairs should be completed in a reasonable amount of time, not to exceed 30 days.

If you have any questions regarding your warranty rights and responsibilities, you should contact Maruyama U.S., Inc. at **1-866-783-7400**, or **warranty@maruyama-us.com**.

Emission System Parts

Exhaust Emission

Carburetor
Muffler
Catalytic Converter
Ignition Coil / Magneto
Spark Plug
Air Filter
EGR Valve (piston)
Fuel Filter

Evaporative Emission

Fuel Tank



WARNING



1. Read and understand this Owner's/Operator's Manual before using this product. Be thoroughly familiar with the proper use of this product.
2. Do not allow children to operate this product. It is not a toy. Never allow adults to operate the unit without first reading the Owner's / Operator's Manual.
3. Become familiar with the controls and know how to stop the engine quickly.
4. Always use eye protection and hearing protection.
5. Keep the area of operation clear of all persons, particularly small children and pets.
6. Do not point the pipe in the direction of people or pets.
7. Do not operate a product when you are fatigued, sickness, intoxicated, and pregnant.
8. Do not operate a product without proper guards or other protective safety devices in place.
9. Dress properly; do not wear loose clothing or jewelry that can be caught in moving parts. Always wear substantial footwear, long pant, and long sleeved shirt.
10. Gasoline is highly flammable; handle it carefully.
 - A. Do not smoke while handling gasoline.
 - B. Use an approved fuel container for storing the gasoline/oil mixture.
 - C. Do not fill the fuel tank when the engine is hot or running
 - D. Fill the fuel tank outdoors and only up to one-half inch from the top of the tank. Do not fill the filler neck.
 - E. Wipe away any spilled gasoline before starting the engine.
11. Always be sure of your footing; keep a firm hold of the blower pipes, and walk, do not run while operating a mist blower.
12. Use the correct accessories. Do not use this product for any job except that for which it is intended.
13. Keep all fasteners tight and be sure this product is in safe working condition. Follow the maintenance instructions provided on page 10 - 11 of this manual.
14. Do not put hands or feet near or under the rotating parts. Keep clear at all times.
15. If this product should start to vibrate abnormally, stop the engine immediately and check for the cause. Vibration is generally a warning of trouble.
16. Avoid using this product near rocks, gravel, stones and similar matter in order to avoid dangerous flying debris.
17. Use this product only in daylight or good artificial light.
18. Do not allow bystanders in work area.
19. Do not operate in unventilated area.
20. To reduce the risk of injury associated with the inhalation of dust, use a face filter mask in dusty conditions.
21. To reduce the risk of injury associated with contacting rotating part, stop the engine before installing or removing attachments.
22. To reduce the risk of fire and burn injury:
 - Move at least 10ft (3m) away from the fueling point before starting engine.
 - Always store gasoline in approved container.

Operating techniques

- A. Operate power equipment only at reasonable hours - not early in the morning or late at night when people might be disturbed. Comply with times listed in local ordinances. Usual recommendations are 9:00 am. to 5:00 p.m., Monday through Saturday.
- B. To reduce noise levels, limit the number of pieces of equipment used at any one time.
- C. To reduce noise levels, operate mist blowers at the lowest possible throttle speed to do the job.
- D. Check your equipment before operation, especially the muffler, air intakes, and air filters.
- E. Use rakes and brooms to loosen debris before blowing.
- F. In dusty conditions, slightly dampen surfaces when water is available.
- G. Conserve water by using mist blowers instead of hoses for many lawn and garden applications, including areas such as gutters, screens, patios, grills, porches, and gardens.
- H. Watch out for children, pets, open windows, or freshly washed cars, and blow debris safely away.
- I. Use the full blower nozzle extension so the air stream can work close to the ground.
- J. After using this product and other equipment, CLEAN UP! Dispose of debris in trash receptacles.

SPECIFICATIONS

Models	MM181
Dimensions L x W x H	375 x 480 x 590 mm
Dry Weight	11.2 kg
Engine Type	Kawasaki/2-Stroke Air cooled TK65 for EPA
Displacement	64.7 cc
Ignition System	Electric
Carburetor	All position diaphragm
Chemical Tank Capacity	13 lit
Fuel Tank Capacity	2 lit
Fuel Mixture	50:1 Using MARUYAMA 50:1 2-stroke Engine Oil or ISO JASO-FD 2-stroke engine oil designed for use in air-cooled, high performance 2-stroke engines.
Attachments (Standard)	Flexible Pipe, Swivel Pipe Straight Pipe, Mist Pipe

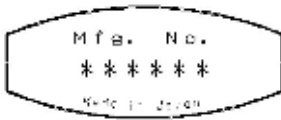

SERIAL NIMBER

At the Rated Operation (Engine Rotational Speed : 6350 min⁻¹)
 Vibration Value :3.87 m/s² (Shoulder Bearing Part)
 Noise emissions Sound power level, measured, dB(A) 108
 Sound power level, guaranteed, LWAG dB(A) 109
 Safety Inclination Degree is within 10°.

The MARUYAMA MIST BLOWER comes with an Owner's / Operator's Manual and a Warranty Registration Card. Assembly and attachment of the throttle lever bracket and blower pipes are required.

ASSEMBLY INSTRUCTIONS

STEP #1) Locate and identify all the components (see sketch).

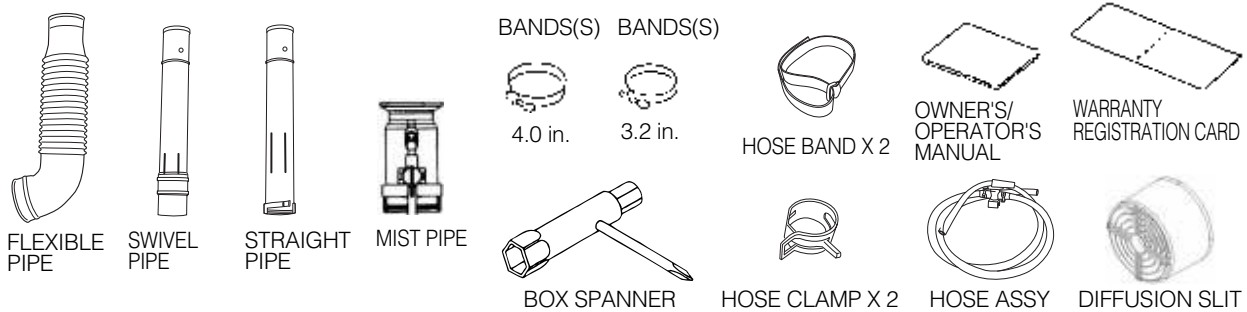

STEP #2) Using the BANDS, connect the FLEXIBLE PIPE to the blower, and the SWIVEL PIPE to the flexible pipe (see sketch).

STEP #3) Assemble the STRAIGHT PIPE, and MIST PIPE, then connect them to the swivel pipe (see sketch).

STEP #4) Slide handle over swivel pipe and tighten retainer knob. (see sketch).

STEP #5) Connect the Mist hose to the Mist cock and Mist pipe. (see sketch)

OPTION PARTS

MIST DEFLECTOR CAP

ONE WAY TYPE

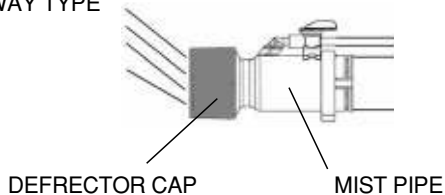

DUAL TYPE

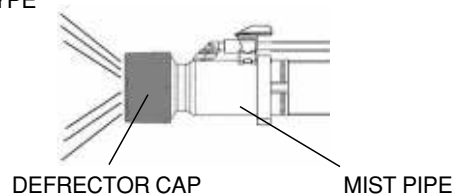

NAME OF EACH PART

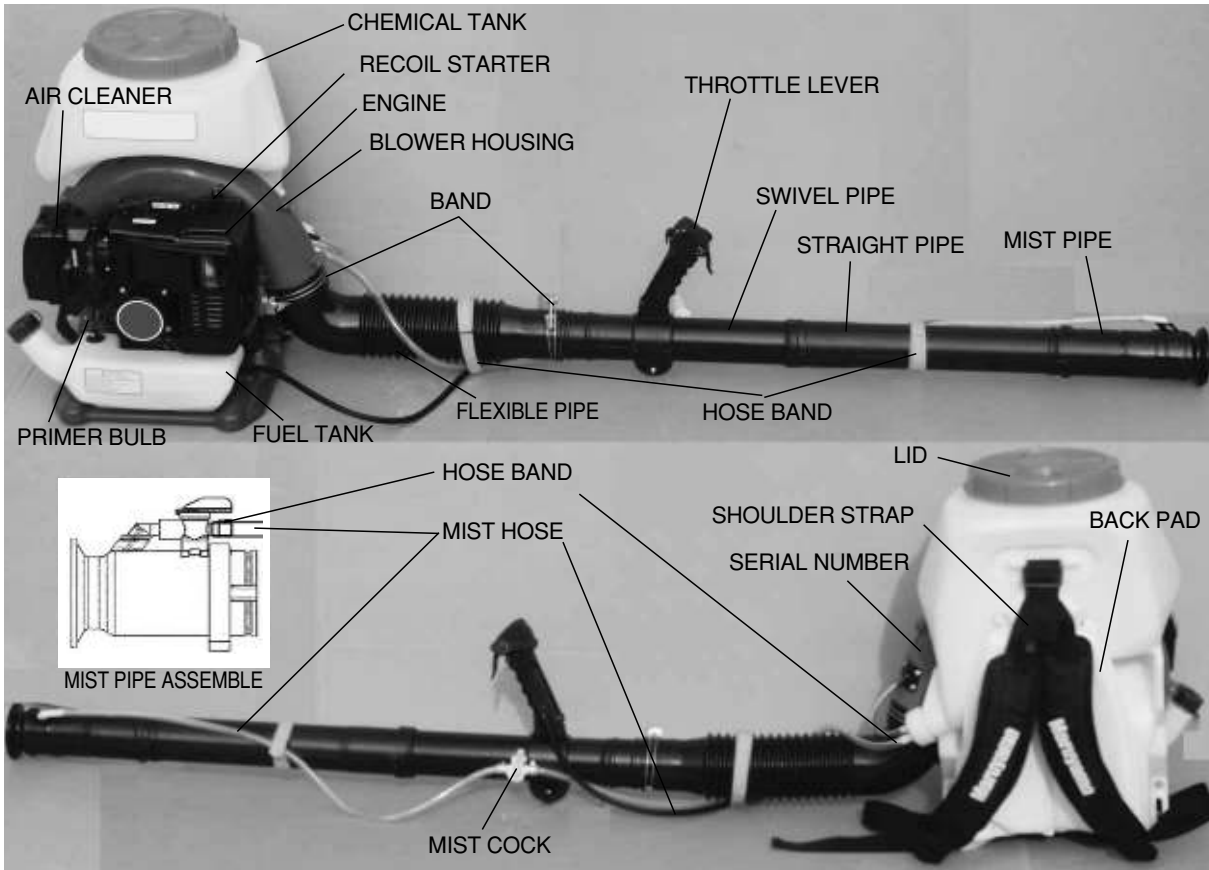

MIST COCK SETTING PROCEDURE



MIST HOSE HOSE CONNECT

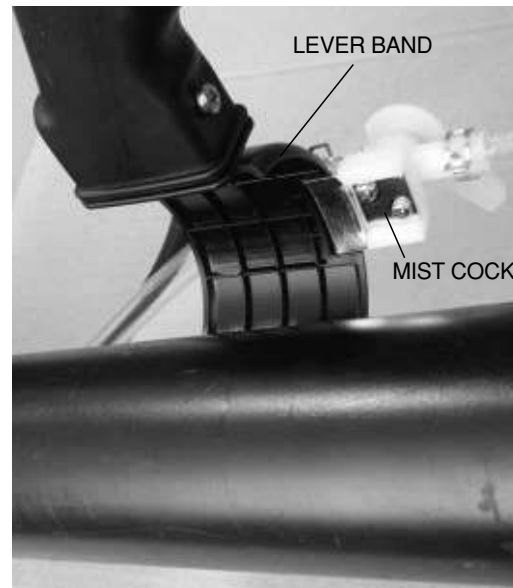

SET METAL FITTINGS OF "MIST COCK" IN THE "LEVER BAND".

BEFORE OPERATION

FUEL: MIXING GASOLINE AND OIL

CAUTION! The engine used on this product is of a 2-stroke design. The internal moving parts of the engine, i.e., crankshaft bearings, piston pin bearings and piston to cylinder wall contact surfaces, require oil mixed with the gasoline for lubrication. Failure to add oil to the gasoline or failure to mix oil with the gasoline at the appropriate ratio will cause major engine damage which will void your warranty. For your fuel premix, only use Maruyama 50:1 2-Stroke Oil or JASO-FD of equivalent ISO-LEGD for 2-stroke air-cooled engine.

FUEL MIXTURE: When using genuine Maruyama 50:1 2-Stroke Oil, or a quality oil designed for 2-stroke air-cooled engines, oil ratio is 50 parts gasoline to 1 part oil or 50:1.

CAUTION! If Maruyama brand oil is not used, never use a mixing ratio less than 50:1 regardless of the oil package mixing instructions. Ratios less the 50:1, reduce the amount of lubrication to the internal moving parts of the engine and can cause damage.

MIXING INSTRUCTIONS: Always mix fuel and oil in a clean container approved for gasoline. Mark the container to identify it as fuel mix for the product. Use regular unleaded gasoline and fill the container with half the required amount of gasoline. Pour the correct amount of oil into the container then add the remaining amount of gasoline. Close the container tightly and shake it

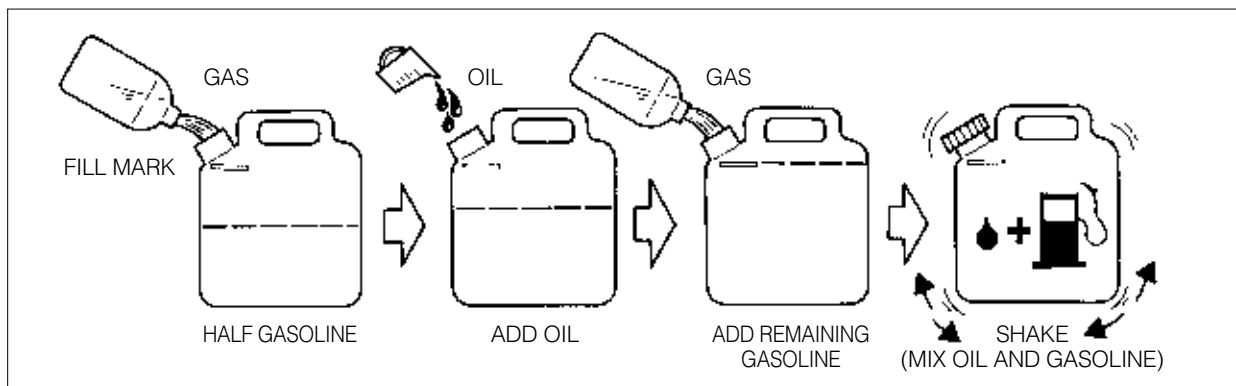

momentarily to evenly mix the oil and the gasoline before filling the fuel tank on the product. When refilling the fuel tank, clean around the fuel tank cap to prevent dirt and debris for entering the tank during cap removal. Always shake the premix fuel container momentarily before filling the fuel tank.

Always use a spout or funnel when fueling to reduce fuel spillage. Only fill the tank to within 1/2 inch from the top of the tank. Avoid filling to the top of the tank filler neck.

NOTE:

1. Do not mix gasoline and oil directly in the product fuel tank.

CAUTION!

1. Do not use National Marine Manufacturer's Association (NMMA) or BIA certified oils. This type or 2-stroke engine oil does not have the proper additives for air-cooled, 2-stroke engines and can cause engine damage.
2. Do not use automotive motor oil. This type of oil does not have the proper additives for air cooled, 2-stroke engines and can cause engine damage.

Be sure the mist blower is correctly assembled and all fasteners and fittings are properly secured.

THROTTLE LEVER

Before operating the mist blower, release the knob, knob the throttle grip to the position in the illustration, and tighten knob to secure in place.

When the mist blower is strapped to the back of the operator, the throttle lever of is located on the tube.



CAUTION!

1. Shutting Engine Off

Before shutting the engine off, allow it to idle for a short while.

- Never stop the engine by closing the choke.
- Never stop the engine during operation while running above idle speed.

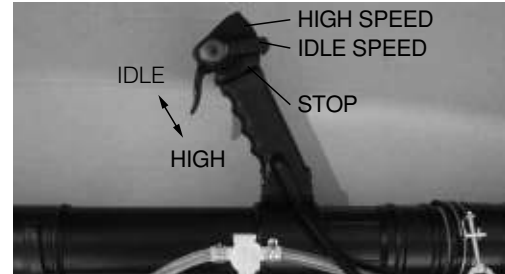

2. Transporting and Storage

- Shut off the engine and allow it to cool before transporting or storing the unit.
- Do not put the unit on dry grass or near any flammable object unless the engine is cold or cooled down.

The lowest position of lever is "STOP" setting, and the highest position is the "FULL THROTTLE" setting.

Chemicals

- *Read the labels of chemicals to be used carefully and understand the method of use and cautions. Use the chemicals directly after opening the package. Chemicals left for a long time after the package is open may cause poor discharging due to moisture absorption.
- *Mistaking the discharge quantity re category of chemicals may cause damage.
- *Do not leave the chemicals in the chemical tank for a long time. The machine might malfunction.
- *Store chemicals in a safe place, and be careful not to break open their containers during transportation.
- *Treat chemical containers to ensure safety.
- *Dispose the used chemical or fertilizer bags in a manner that will not cause injury.
- *Pay attention to the handling of chemicals and fertilizer. If a chemical enters into eye or mouth, wash it off with water immediately. If you feel ill, see a doctor immediately.
- *According to wind direction, change the discharging method to protect workers and houses. When discharging chemicals, work from upwind to downwind. Also give consideration to prevent chemicals from drifting or scattering on crops, enclosures, fish-breeding ponds, and houses nearby.
- *When preparing chemicals, prepare the necessary amount only in accordance with the established spraying plan. If too much chemicals are left over, action is difficult.

OPERATING INSTRUCTIONS

STARTING PROCEDURE

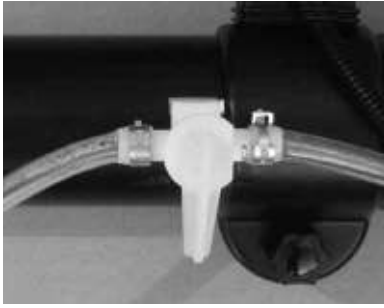

Step#1) Move the "Mist cock" to the closed position.



Do not spill the liquid

Step#2) Pour chemical into the chemical tank.

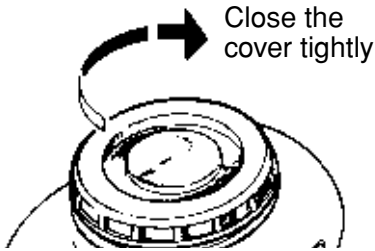

Close the cover tightly

Step#3) Close the lid tightly.

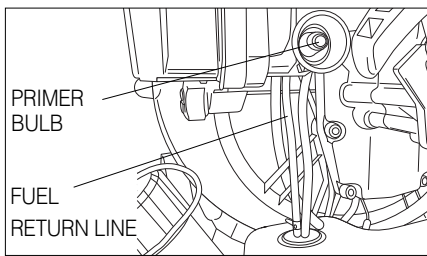

PRIMER BULB

FUEL RETURN LINE

STEP #4) Pump the "PRIMER BULB" under of the carburetor until fuel can be seen flowing through the "FUEL-RETURN LINE".

If a MARUYAMA engine fails to start after following the above procedures, contact an authorized MARUYAMA dealer.

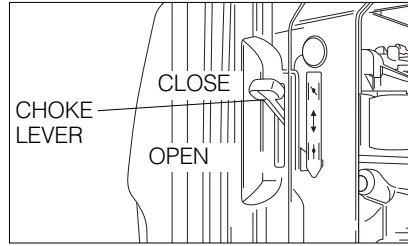

CHOKE LEVER

CLOSE

OPEN

STEP #5) Move the "CHOKE LEVER" fully upward to the closed position. If the engine is already warm, only a partial or open (no choke) choke setting may be required.

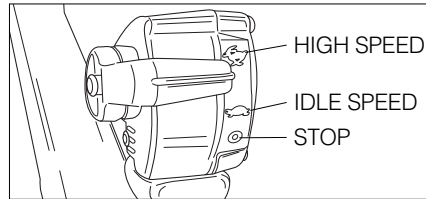

HIGH SPEED

IDLE SPEED

STOP

STEP #6) Set the throttle lever at 1/2 speed.

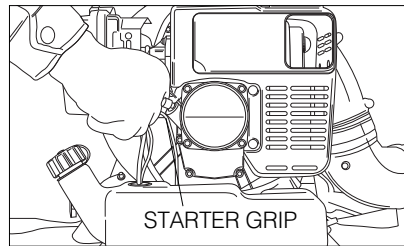

STARTER GRIP

CAUTION! Pull the "STARTER GRIP" briskly to start the engine.

NOTE: Only short pulls are necessary. Never pull the starter cord to its fullest extension. Never let go of the starter grip until it is at the fully returned position.

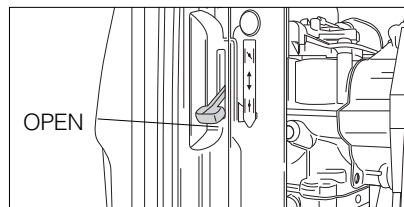

OPEN

STEP #7) Warming up the engine. When the engine has started, slowly move the "CHOKE LEVER" fully upward to the open position. Allow the engine to "WARM-UP" at less than 1/2 speed.

OPERATION

When the engine has warmed-up, the mist blower can be positioned on the back of the operator. When the mist blower is positioned and ready for operation, adjust the throttle to a speed required to accomplish the task.

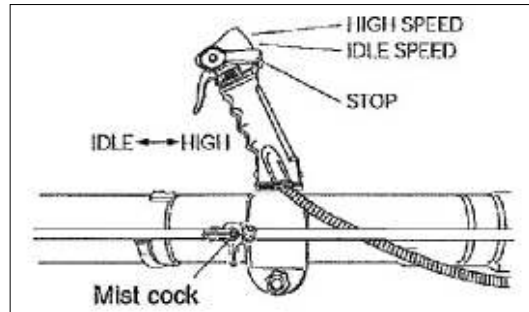

1. Mist cock

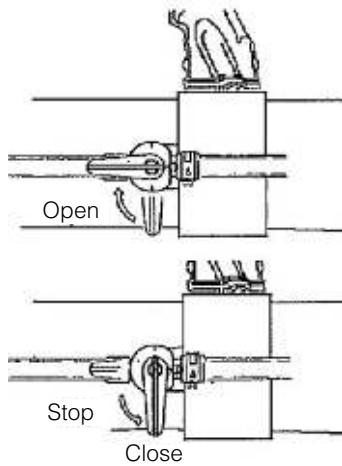

2. Adjustment of discharging volume

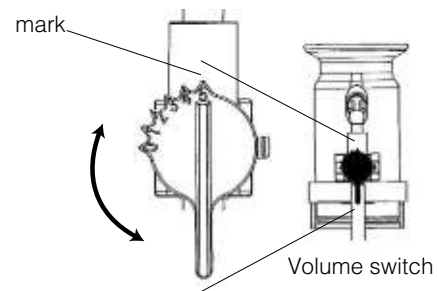

- Coincide the number on the dial of volume switch with the market.
- Discharging volume will increase accordingly as the number increases.

Discharging volume

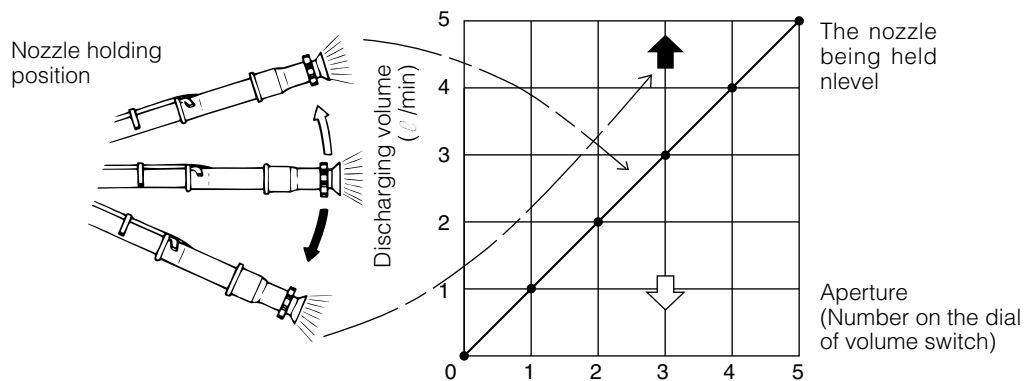

CAUTION

- Avoid using too dense hydrate solution.

! WARNING

- Never operate a mist blower when you are fatigued.
- Never operate a mist blower without proper guards or other protective safety devices in place.

! WARNING

To prevent overheating and engine seizure, cooling air comes from the intake grille of the fan housing and is pushed by the blower fan through an opening in the fan housing over the cylinder fin area, taking away combustion heat. The grille and cylinder fins must be kept clean of grass, dust and any debris. Engine failure due to lack of this "Normal Maintenance" is not covered by warranty.

STOPPING THE ENGINE

Close the Mist cock, and stop spraying.

Always run the engine at idle speed for a few minutes to allow cooling before stopping. To stop the engine, move the throttle control lever all the way to the engine stop position.

CLEANING THE PRODUCTS

Remove Mist hose from Mist pipe, and discharge chemical from chemical tank.

After recovering the remnant chemical, clean the inside chemical tank using clean water.



Also wash the spray nozzle with clear water.

REGULAR MAINTENANCE

Before each use, the mist blower should be inspected for proper assembly and fitness of all components. All fasteners should be checked for correct tightness. Always inspect for fuel leaks.

! WARNING Do not attempt to start or operate a mist blower that indicates a fuel leak.

AIR FILTER

The air filter should be inspected each time the mist blower is used (or more often with extreme conditions).

To inspect, remove the air filter cover and remove the filter from the case.

Clean air filter(s) by gently tapping element or cleaning with a suitable solvent the filter should be completely dry before using again.

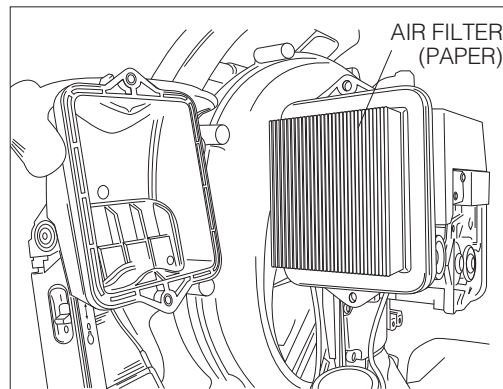

SPARK PLUG

The spark plug should be removed from the engine and checked after each fifty (50) hours of use. The tips can be cleaned with a stiff brush. Adjust the gap to 0.031 - 0.035 inches (see sketch).

Replace the spark plug if it is oil-fouled or damaged.



CAUTION!

The correct torque for the spark plug is 10 - 12 ft. lbs. Do not over-tighten.

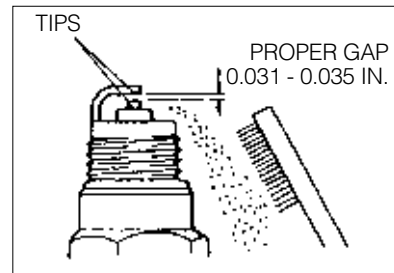

FUEL FILTER

The fuel filter should be cleaned and inspected for damage after each twenty (20) hours of use.

The fuel filter is attached to the fuel pick-up tube inside the fuel tank. Loosen the clamp and take out the fuel filter.

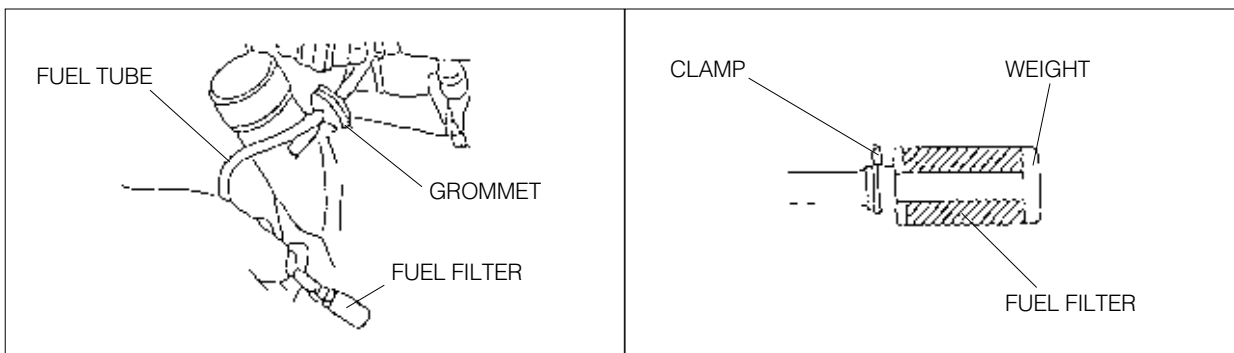

To clean the fuel filter, remove it from the fuel tube and wash it with safety solvent. Inspect and clean the fuel tank before re-installing the fuel filter.

Always replace a defective fuel filter.

COOLING FINS

Free passage of air flow through the cylinder cooling fins is required to prevent poor engine performance and shortened engine life. Regularly check and clean all debris from the cooling fins by removing the engine cover (see sketch).

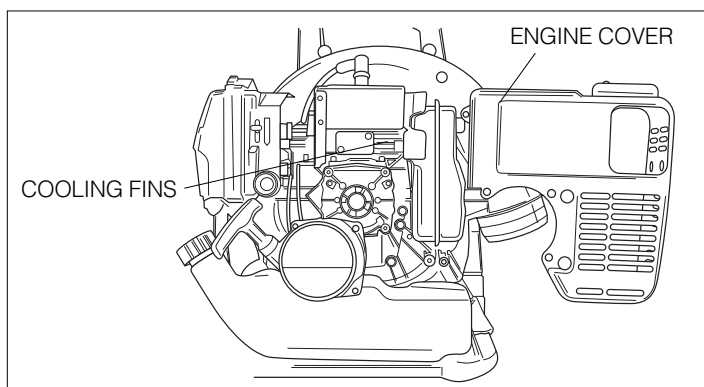

MUFFLER AND EXHAUST PORTS

The muffler should be removed and serviced after each one fifty (50) hours of use. At the same time, the exhaust ports should be cleaned and inspected. An AUTHORIZED MARUYAMA DEALER should be contacted for this service.

GENERAL CLEANING AND TIGHTENING

The MARUYAMA mist blower will provide maximum performance for many hours, if it is maintained properly. Good maintenance includes regular checking of all fasteners for correct tightness, and cleaning the entire machine. Contact an authorized MARUYAMA dealer for additional maintenance suggestions.

SPARK ARRESTER

1. Remove the screw from the muffler.
2. Take the spark arrester out off the muffler, and then clean by brushing it.
3. Return the spark arrester to the muffler.
4. Tighten the screw securely.

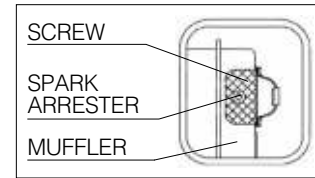

STORAGE

For long-term storage of the mist blower, first perform all regular maintenance procedures and needed repairs. Empty the fuel tank. Disconnect the fuel supply line from the carburetor and depress the primer bulb until fuel stops discharging from the fuel-return line.

Start the engine and allow it to run until it stops. Pull the starter cord a few times to remove any excess fuel from the engine. Remove the spark plug and insert a small amount of oil into the cylinder. Slowly pull the starter cord and bring the piston to a position closest to the spark plug hole. Re-install the spark plug. Apply a thin coating of oil to all the metal surfaces and store the mist blower in a dry place.

EMISSION CONTROL INFORMATION

FUEL INFORMATION

THIS ENGINE IS CERTIFIED TO OPERATE ON UNLEADED REGULAR GRADE GASOLINE ONLY. A minimum of 87 octane of the antiknock index is recommended.

EMISSION CONTROL INFORMATION

To protect the environment in which we all live, Kawasaki has incorporated an exhaust emission control system.

EXHAUST EMISSION CONTROL SYSTEM (EM)

The system reduces the amount of pollutants discharged into the atmosphere by the exhaust of this engine. The fuel, ignition and exhaust systems of this engine have been carefully designed and constructed to ensure an efficient engine with low exhaust pollutant levels. The exhaust system of the engine includes a catalytic converter system.

MAINTENANCE AND WARRANTY

Proper maintenance is necessary to ensure that your engine will continue to have low emission levels. This Owner's/Operator's Manual contains those maintenance recommendations for your engine. Those items identified by the Periodic Maintenance Chart are necessary to ensure compliance with the applicable standards.

As the owner of the Mist Blower, you have the responsibility to make sure that the recommended maintenance is carried out according to the instructions in this Owner's/Operator's Manual at your own expense.

The Maruyama Limited Emission Control System Warranty requires that you return your Mist Blower to an authorized Maruyama Mist Blower dealer for remedy under warranty. Please read the warranty carefully, and keep it valid by complying with the owner's obligations it contains.

TAMPERING WITH EMISSION CONTROL SYSTEM PROHIBITED

Federal law and California State law prohibit the following acts or the causing there of:

(1) the removal or rendering inoperative by any person other than for purposes of maintenance, repair, or replacement, of any device or element of design incorporated into any new engine for the purposes of emission control prior to its sale or delivery to the ultimate purchaser or while it is in use, or (2) the use of the engine after such device or element of design has been removed or rendered inoperative by any person.

Among those acts presumed to constitute tampering are acts listed below:

Do not tamper with the original emission related parts.

- Carburetor and internal parts
- Spark plug
- Magneto or electronic ignition system
- Fuel filter
- Muffler or any internal portion of the muffler
- Air cleaner element
- Fuel tank

FUEL RECOMMENDATIONS

FUEL

The Kawasaki TK series 2-stroke engines require a gasoline-oil mixture. Use only clean, fresh, unleaded regular grade gasoline.

Octane Rating

The octane rating of a gasoline is a measure of its resistance to "knocking". Use of a minimum of 87 octane of the antiknock index is recommended.

NOTE:

- If "knocking or pinging" occurs, use a different brand of gasoline or higher octane rating.

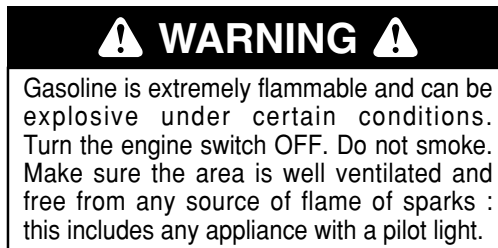

2-STROKE ENGINE OIL MIXING

Gasoline is extremely flammable and can be explosive under certain conditions. Turn the engine switch OFF. Do not smoke. Make sure the area is well ventilated and free from any source of flame or sparks : this includes any appliance with a pilot light.

NOTE:

- Do not mix gasoline and oil directly in the fuel tank.
- The lubricative quality of this mixture deteriorates rapidly.
- Do not use gasoline that has been stored longer than two months.
- To ensure proper starting at low ambient temperatures, fresh winter grade fuel must be used.

CAUTION: The engine is shipped without fuel.

ADJUSTMENT

IDLING SPEED ADJUSTMENT

1. Idle speed is the only available adjustment.
2. Do not tamper with the carburetor setting to increase the maximum engine speed.
3. If adjustment is needed, have it performed by your authorized MARUYAMA service dealer. Carburetor adjustments are made at the factory and are not adjustable without disassembling the carburetor.

MAINTENANCE

PERIODIC MAINTENANCE CHART

⚠ WARNING ⚠

Always remove the spark plug cap from spark plug when servicing the engine to prevent accidental starting.

MAINTENANCE	Interval				
	Daily	First 20 hours	Every 20 hours	Every 50 hours	Every 100 hours
Check and replenish fuel	●				
Check for fuel leakage	●				
Check bolts, nuts and screws for looseness and loss	●				
Clean fuel filter			●		
★ Clean air filter element			●		
Tighten bolts and nuts		●		●	
Clean spark plug and adjust electrode gap				●	
★ Remove dust and dirt from cylinder fins				●	
M Remove carbon deposits on piston head and inside cylinder				●	
M Remove carbon deposits in the exhaust pipe of muffler				●	
M Clean net of spark arrester (if equipped)				●	
M Check the sliding portion of crankshaft, connecting rod etc.					●
Fuel tube	It is recommended to replace every 3 years.				

Note: The service intervals indicated are to be used as a guide. Service to be performed more frequently as necessary by operating condition.

M: Service to be performed by an authorized Maruyama engine dealer.

★: Service more frequently under dusty conditions.



Maruyama U.S., Inc.

4770 Mercantile Drive, suite100,
Fort Worth, TX 76137 U.S.A.

Phone 940-383-7400

Fax 940-383-7466

www.maruyama-us.com

P/N 277167-00 16.02 TAP/F